

Model	Output Current	Input Current	Input Power	Output Power Range	PF	Efficiency	Output Voltage	No load Voltage
CC10W180 Triac	180mA	0.1A	15W	6.48-9W	0.92	78%	36-50V	65V
CC10W200 Triac	200mA	0.1A	15W	7.2-10W	0.92	78%	36-50V	70V
CC10W250 Triac	250mA	0.1A	15W	6.75-10W	0.92	78%	27-40V	60V
CC10W300 Triac	300mA	0.1A	15W	5.7-9W	0.92	78%	19-30V	50V
CC10W350 Triac	350mA	0.1A	15W	6.65-9.8W	0.92	78%	19-28V	50V
CC10W400 Triac	400mA	0.1A	15W	5.2-8.4W	0.92	78%	13-21V	40V
CC10W450 Triac	450mA	0.1A	15W	5.85-9.45W	0.92	78%	13-21V	40V
CC10W500 Triac	500mA	0.1A	15W	6.5-10.5W	0.92	78%	13-21V	40V
CC10W550 Triac	550mA	0.1A	15W	4.4-7.15W	0.92	78%	8-13V	30V
CC10W600 Triac	600mA	0.1A	15W	4.8-7.8W	0.92	78%	8-13V	30V
CC10W650 Triac	650mA	0.1A	15W	5.2-8.45W	0.92	78%	8-13V	30V
CC10W700 Triac	700mA	0.1A	15W	5.6-9.1W	0.92	78%	8-13V	30V

\* Test result @230V, 50Hz, Full Load.

### 1. Parameters

category	Item	Technical Norm
Features	Output Type	Constant Current
	Dimming Type	Phase dimming
	Dimming Range	10%-100%
	IP Grade	IP20
	Insulation Class	Class II
Input	Rated Input Voltage	220-240VAC_stable
	Range of Input Voltage	198-264VAC_stable or 180-280VDC_stable
	Frequency	50/60Hz
	Input Current	≤0.1A
	Input Power	≤ 15W
	Power Factor	≥0.92 (230VAC,full load)

	No-load Power Consumption	≤1W @230VAC
	Inrush Current	≤10A/400us (230VAC,full load)
	Connected quantity of 16A Breaker	60pcs/type B ;96pcs/type C @ 230Vac
Output	Current Accuracy	±5%
	Max. Output Power	10.5W
	Started Delay Time	≤1S (230VAC,full load)
	Current Ripple(< 120 Hz)	±5% (Imax-Imin) /(Imax+Imin)
	PstLM	≤1
	SVM	≤0.4
Protection	Short Circuit Protection	Auto Recovery
	Overload Protection	Auto Recovery
	No-load Protection	Auto Recovery
	Insulation voltage	I/P to O/P , 3.0KVac/5mA/1min
	Insulation resistance	>100M ohm @ 500VDC
	Leakage current	I/P to O/P < 250μA
Environment	Ta/Operation Temperature	-20....+50℃
	Ts/Storage Temperature	-40....+85℃
	Tc/Enclosure Temperature	85 ℃
	Humidity	10%....90%RH
	Atmosphere	86-108KPa
Construction	Connection Method	Direct Lead
	Installation	Build-in
	PRI Wire preparation	0.5-1.5 <sup>□</sup>
	SEC Wire preparation	0.5-1.5 <sup>□</sup>
	Dimension	58.2*36*20mm (L*W*H)
Standards	Certification	TUV、CE、SAA
	Safety Standards	EN61347-1:2015,EN61347-2-13:2014/A1:2017, EN62493:2015,AS/NZS IEC61347.2.13:2018, AS/NZS61347.1:2016 Inc AI
	EMC Standards	EN IEC 55015:2019,EN IEC 55015:2019/A11:2019, EN IEC 61000-3-2:2019, EN 61000-3-3:2013/A1:2019,EN61547:2009
	Performance	EN62384
	Surge	L-N/ 1KV
Others	RoHS	complied to 2011/65/EU
	Life Time	50000h @ Ta/Tc
	Warranty	5years , F.R. < 10000ppm
	Noise	15cm <28dB

**Remark**

- All Parameters, if not specified, are measured at 230VAC/50Hz and 25℃ ambient temperature.
- LED Driver is a component of the luminaires. Luminaires and wire layout will affect the EMC, please check the

EMC with end products again.

**2. Trailing Edge Dimmer list approved by KGP**

Manufacturer	Model	Q'ty of parallel connection
ABB	6519 U	12
ABB	6526 U	11
JUNG	1224 LED UDE	12
Berker	2861	12
JUNG	254 UDIE 1	13
JUNG	225 TDE	12
EGANT	U321V2	12
Schneider	SBD200LED	13
Schneider	SBD315RC	12
Merten	SBD200LED	13
Berker	2874	12
Eltako	EUD61NPL-230V	10
Eltako	EUD12NPN-UC	10
Eltako	EUD12D-UC	10
Eltako	EUD61NP-230V	10
Eltako	DTD55L-230V-wg	10
GIRA	Universal-LED-Dimmer Mini2440 00	10
EHMANN	LED-Dimmer T46.08	9
JUNG	DrehDimmer Universal LED1731DD	10
EHMANN	LED-Dimmer T46.03	10

***Leading Edge Dimmer list only on request -/ or confirmed by KGP Electronics***

**3. Label (For example)**

### 4. Dimming curve

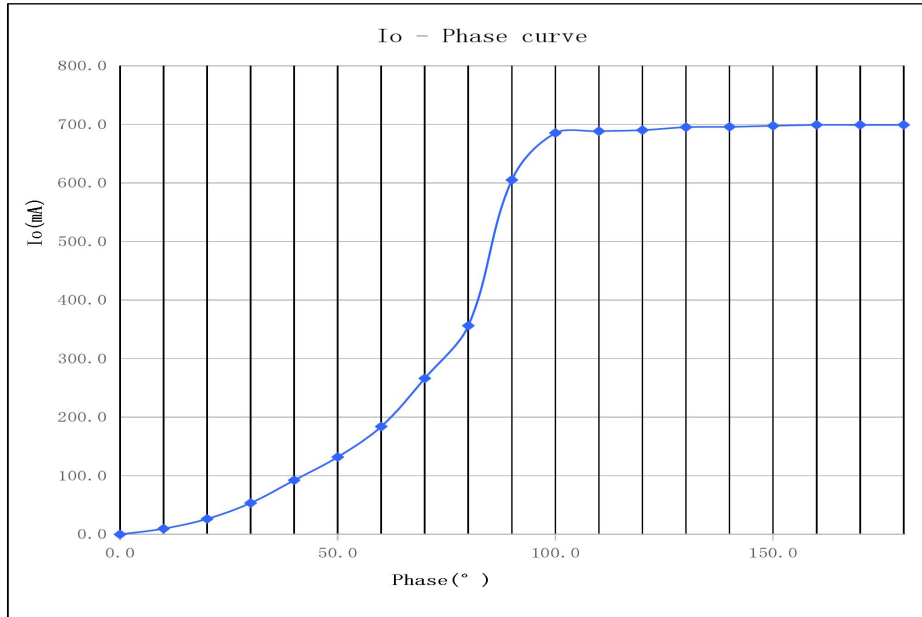

### 5. Lifetime curve

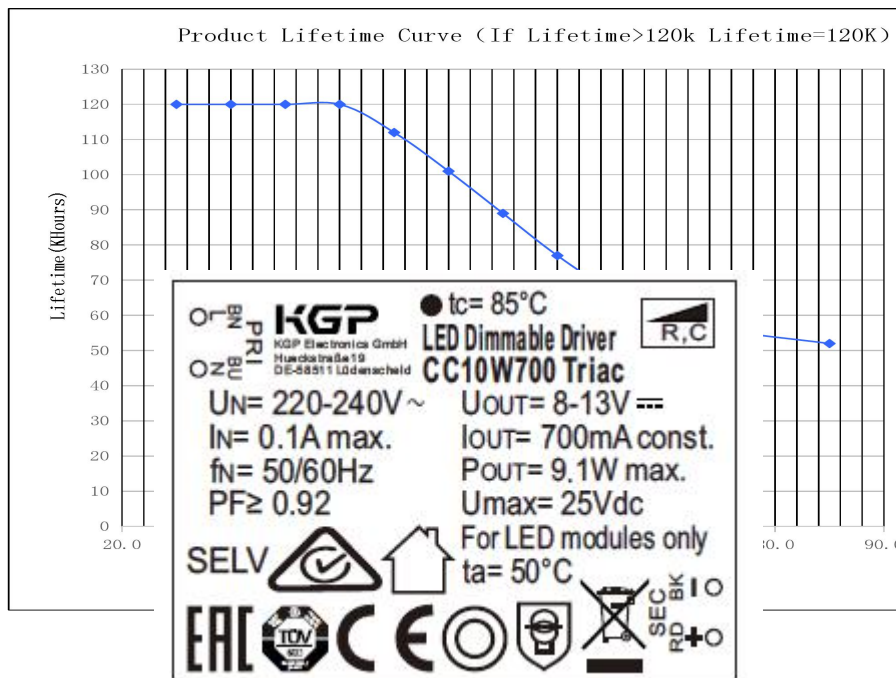

### 6. Dimension (Unit: mm)

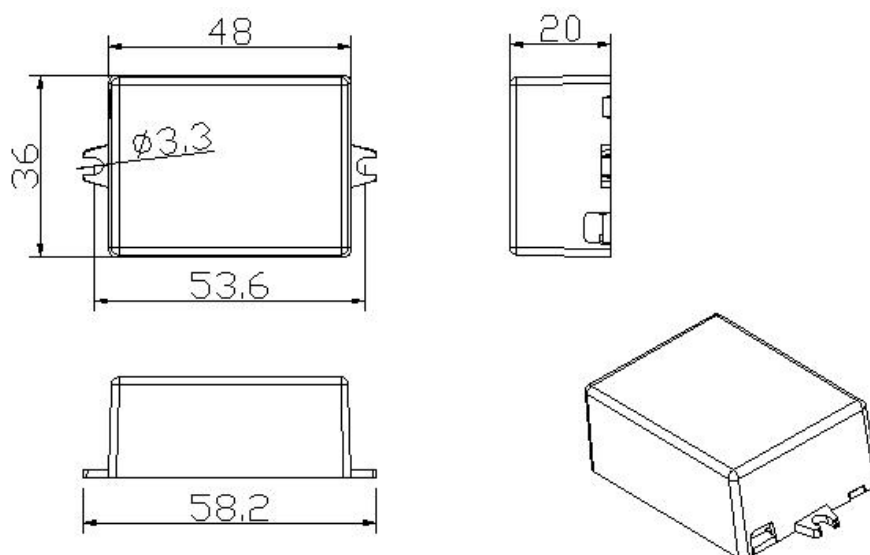

### 7. Packing information

Carton L*W*H(mm)	Pcs/Carton	Net weight/ Pcs(kg)	Net weight/ Carton(kg)	Gross weight / Carton(kg)
450*240*200	150	0.065	9.75	10.5

### 8. Wiring Diagram

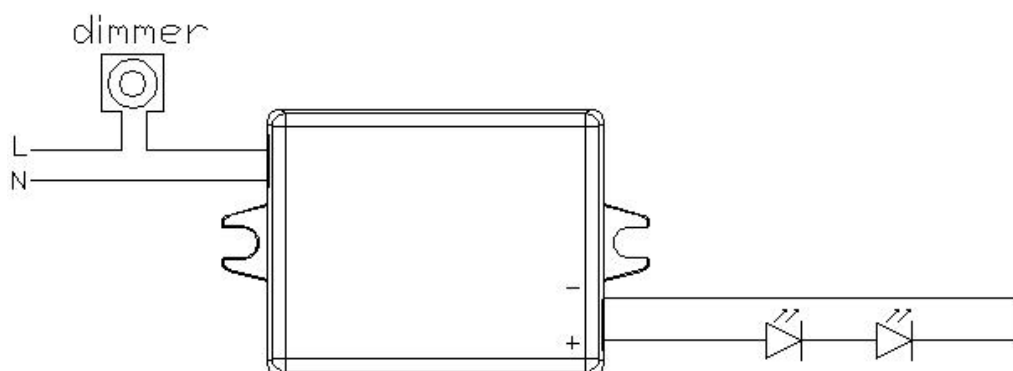

### 9. Wiring instructions

- All connections must be kept as short as possible to ensure good EMI behaviour
- Mains leads should be kept apart from LED Driver and other leads (ideally 5 – 10 cm distance)
- Advice the maximum length of output wires is 3 m
- Secondary switching is not permitted (Except for constant voltage)
- Incorrect wiring can damage LED modules.
- The wiring must be protected against short circuits to earth (sharp edged metals parts, metal cable clips, louver, etc.)

KGP Electronics GmbH  
Hueckstraße 19  
DE-58511 Lüdenscheid