



CC36W500-700CG Triac/CC36W700-900CG Triac



Constant Current & Dimmable Driver

**Model: CC36W500-700CG Triac
CC36W700-900CG Triac**



Model	Output Current (230V Full Load)	Input Current (230V Full Load)	Input Power (230V Full Load)	Output Power Range	PF (Full Load)	Efficiency (Full Load)	Output Voltage	No load Voltage
CC36W500-700CG Triac	500mA	0.16A	30W	15-26W	0.92	85%	30-52V	65V
	550mA	0.16A	35W	16.5-28.6W	0.92	85%	30-52V	65V
	600mA	0.22A	40W	18-31.2W	0.92	86%	30-52V	65V
	700mA	0.22A	45W	21-36.4W	0.92	86%	30-52V	65V
CC36W700-900CG Triac	700mA	0.16A	30W	18.2-28W	0.92	85%	26-40V	55V
	800mA	0.16A	35W	20.8-32W	0.92	85%	26-40V	55V
	850mA	0.22A	40W	22.1-34W	0.92	85%	26-40V	55V
	900mA	0.22A	45W	23.4-36W	0.92	85%	26-40V	55V

* Test result @230V, 50Hz, Full Load.

1. Parameters

category	Item	Technical Norm
Features	Output Type	Constant Current
	Dimming Type	Phase dimming
	Dimming Range	10%-100%
	IP Grade	IP20
	Insulation Class	Class II
Input	Rated Input Voltage	220-240VAC_stable
	Range of Input Voltage	198-264VAC_stable or 180-280VDC_stable
	Frequency	50/60Hz
	Input Current	≤0.24A
	Input Power	≤45W
	Power Factor	≥0.92 (230VAC,full load)
	THD	≤20% (230VAC,full load)
	No-load Power Consumption	≤1W @230VAC
Inrush Current	≤30A/500us (230VAC,full load)	

	Connected quantity of 16A Breaker :	20pcs/type B ; 32pcs/type C
Output Voltage	CC36W500-700CG Triac	30-52V
	CC36W700-900CG Triac	26-40V
Output Current	CC36W500-700CG Triac	500mA/550mA/600mA/700mA
	CC36W700-900CG Triac	700mA/800mA/850mA/900mA
No Load Voltage	CC36W500-700CG Triac	65VDC Max.
	CC36W700-900CG Triac	55VDC Max.
Output	Max. Output Power	36.4W
	Efficiency	≥85%
	Current Ripple (<120Hz)	±5% (Imax-Imin)/(Imax+Imin)
	PstLM	≤1
	SVM	≤0.4
	Current Accuracy	±5%
	Started Delay Time	≤0.5S (230VAC,full load)
Protection	Short Circuit Protection	Auto Recovery
	Overload Protection	Auto Recovery
	No-load Protection	Auto Recovery
	Insulation voltage	I/P to O/P , 3.75KVac/1min
	Ta/Operation Temperature	-20....+45℃
Environment	Ts/Storage Temperature	-40....+85℃
	Tc/Enclosure Temperature	85℃
	Humidity	10%....90%RH
	Atmosphere	86-108KPa
	Connection Method	Push-in Terminal
Construction	Installation	Independent & Built in
	PRI Wire preparation	0.75-1.5 [□]
	SEC Wire preparation	0.5-1.5 [□]
	Dimension	Independent:137.6*44*30mm (L*W*H) Built in:97.8*44*30mm(L*W*H)
	Certification	complied to CE ENEC SAA
Standards	Safety Standards	EN61347-1:2015, EN61347-2-13:2014/A1:2017 EN62384:2006/A1:2009 , AS61347.2.13:2018, AS/NZS61347.1:2016 Inc A1
	EMC Standards	EN IEC55015:2019, EN IEC55015:2019/A11:2019, EN IEC61000-3-2:2019, EN 61000-3-3:2013/A1:2019,EN61547:2009
	Performance	EN62384
	Surge	L-N/1KV
	RoHS	complied to 2011/65/EU
Others	Life Time	50000h @45℃ (Ta) / 85℃ (Tc)



CC36W500-700CG Triac/CC36W700-900CG Triac

Warranty	5years , F.R. < 10000ppm
Noise	15cm <28dB

Remark: 1. Specific instructions are not all parameters are not connect dimmer input voltage 230 vac / 50 Hz and 25 °C ambient temperature measured.
2. LED Driver is a component of the luminaires, Luminaires and wire layout will affect the EMC, please check the EMC with end products again.
3. Trailing edge dimmable.

2. Trailing Edge Dimmer list approved by KGP

Manufacturer	Model	Q'ty of parallel connection
ABB	6519 U	12
ABB	6526 U	11
JUNG	1224 LED UDE	12
Berker	2861	12
JUNG	254 UDIE 1	13
JUNG	225 TDE	12
EGANT	U321V2	12
Schneider	SBD200LED	13
Schneider	SBD315RC	12
Berker	2874	13
Eetako	EUD61NP-230V	12
Eetako	DTD55L-230Vwg	10
GIRA	Universal-LED-Dimmer Mini2440 00	10
EHMANN	LED-Dimmer T46.08	10
JUNG	DrehDimmer Unlversal LED1731DD	10

Leading Edge Dimmer list only on request -/ or confirmed by KGP Electronics

3. Label



KGP LED Dimmable Driver
KGP Electronics GmbH
 Hueckstraße 19
 DE-58511 Lüdenscheid

CC36W500-700CG Triac R.C
 Constant Current Type For LED modules only

$U_N = 220-240Vac$ 50/60Hz $\lambda: \geq 0.92C$
 $U_{out} = Max. 65Vdc$ SELV

PIN1	PIN2	I_o (mA)	P_o (W)	U_{out} (V)	I_r (A)
OFF	OFF	500	26	30-52	0.16
OFF	ON	550	28.6		
ON	OFF	600	31.2	30-52	0.22
ON	ON	700	36.4		

8mm
 PRI 0.75-1.5 □
 SECO. 5-1.5 □
 $t_c = 85^\circ C$
 $t_a = -20^\circ C - +45^\circ C$

EAC







KGP LED Dimmable Driver
KGP Electronics GmbH
 Hueckstraße 19
 DE-58511 Lüdenscheid

CC36W700-900CG Triac R.C
 Constant Current Type For LED modules only

$U_N = 220-240Vac$ 50/60Hz $\lambda: \geq 0.92C$
 $U_{out} = Max. 55Vdc$ SELV

PIN1	PIN2	I_o (mA)	P_o (W)	U_{out} (V)	I_r (A)
OFF	OFF	700	28	26-40	0.16
OFF	ON	800	32		
ON	OFF	850	34	26-40	0.22
ON	ON	900	36		

8mm
 PRI 0.75-1.5 □
 SECO. 5-1.5 □
 $t_c = 85^\circ C$
 $t_a = -20^\circ C - +45^\circ C$

EAC

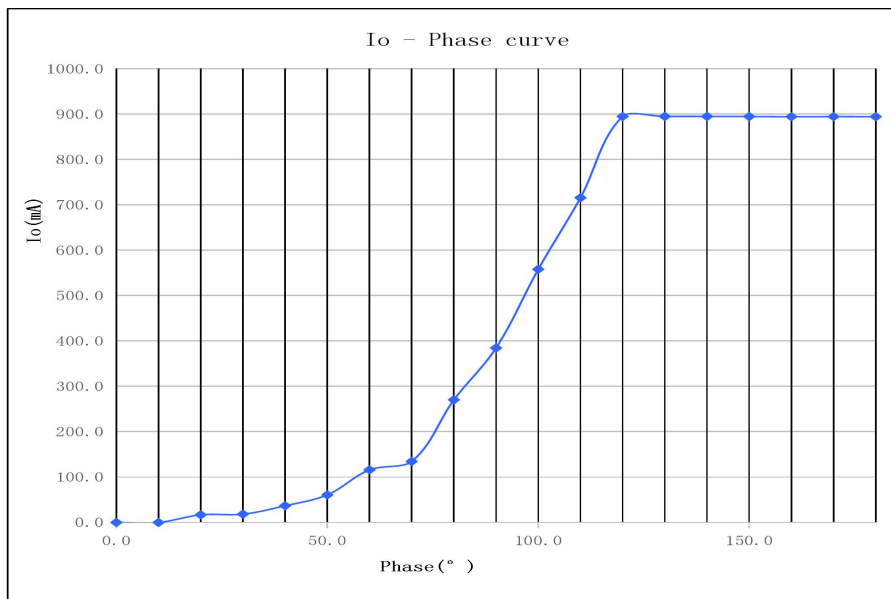

4. Dimming curve

5. Lifetime curve

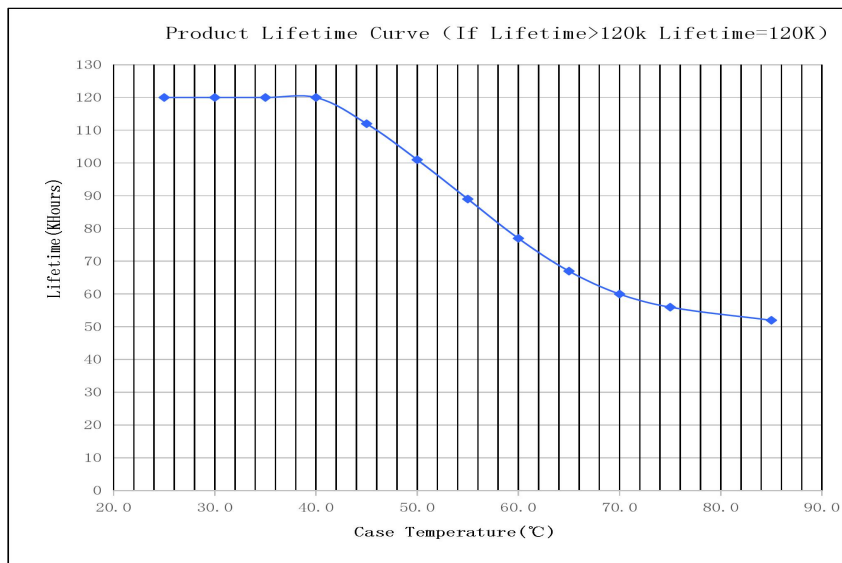

6. Dimension (Unit: mm)

Independent type:

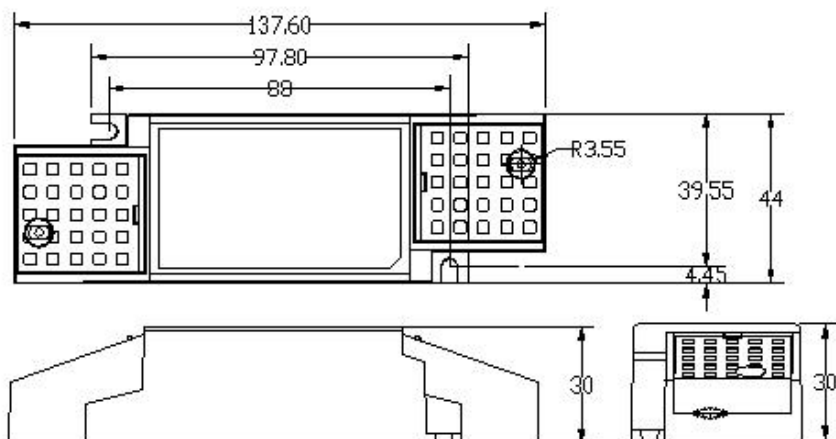

Built in type:

7. Packing information

Carton L*W*H(mm)	Pcs/Carton	Net weight/ Pcs(kg)	Net weight/ Carton(kg)	Gross weight / Carton(kg)
450*240*200	70	0.13	9.1	10.75

8. Wiring Diagram

Independent type:

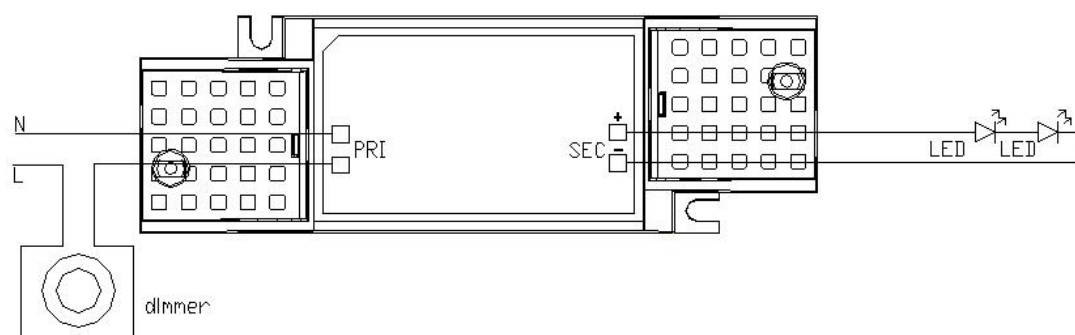

Built in type:

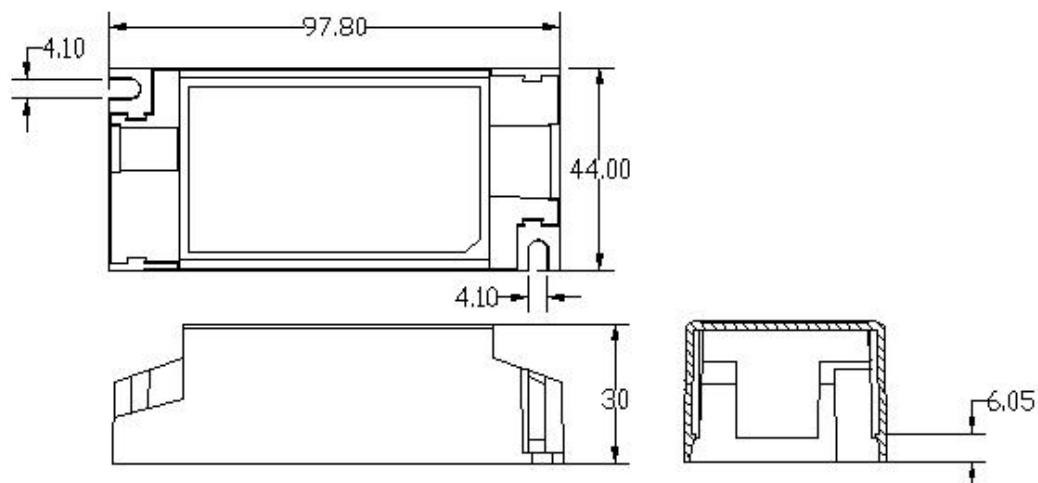
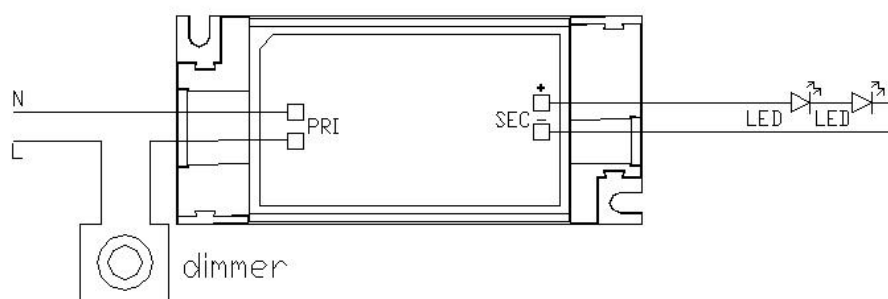



CC36W500-700CG Triac/CC36W700-900CG Triac